

Floor Frame for Wall Mount Change Tables Part Number 19-98-FL

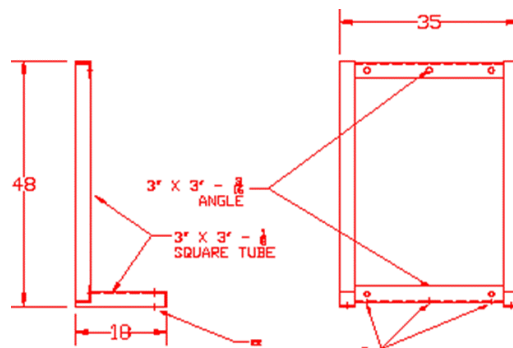

Measurements:



* REAR: 3 - HEX BOLTS 3/8 X 3.5 WITH 2 1/2 LAG SHIELD (DRILL 5/8 HOLE)
 ** FRONT: 2 - HEX BOLTS 5/16 X 2.5 WITH 1 3/4 LAG SHIELD (DRILL 1/2 HOLE)
 ALL HARDWARE INCLUDED WITH FLOOR FRAME

Weight of unit: 25 kg (55 lbs.)

Product Group: Change Tables

Description: The Floor Frame for Wall Mount Changing Table allows the wall mounted change table solution to be supported by the floor frame instead of mounting to the wall in such situation when the walls within the space (room) are not structured to be load bearing. The floor frame is bolted directly into the floor.

Materials: Suitable for use in schools, clinics, private homes and other caregiving situations. Powder-coated steel frame.

Colour: White

Warranty: Can-Dan Rehatec Ltd. as manufacturer warrants from the DATE OF DELIVERY TO THE FIRST CONSUMER that each item described below, as NEW AND UNUSED, will be free from any defects in material and/or workmanship for a period of:

- Four (4) years on Frame (Manufactured by Can-Dan Rehatec Ltd.)